

Power Xpert UX
High-voltage switchgear system

Maximizing
performance
and **safety**



EATON

Powering Business Worldwide



PT. APINDO MITRA SELARAS

Telp. +62 821 2222 8303 - aris@kseindonesia.com
sales@kseindonesia.com - www.kseindonesia.com

A high-performance solution for high-voltage power distribution

Eaton's Power Xpert UX™ IEC high-voltage switchgear system is designed for your most critical applications. At Eaton, our focus is to develop the latest in power distribution and protection technologies to optimize the performance of your installation, while keeping your personnel and equipment safe. With over 90 years of experience in high-voltage switching and vacuum technology, Eaton is best placed to provide the right equipment for the most demanding applications.



The Power Xpert UX high-voltage switchgear system showcases Eaton's heritage of expertise, industry-leading component technology and power distribution system design. This feature-rich platform ensures minimum process interruptions and delivers increased reliability and safety.

Power Xpert UX is a fully scalable system, enabling you to create an optimized high-voltage switchgear solution with fully IEC type tested ratings up to 50kA/4000A.

A truly global platform, the Power Xpert UX switchgear system is designed according to the latest IEC standards and fully supported from our manufacturing facilities around the world. Eaton's delivery model has the ability to meet your most challenging project requirements. The model allows you to standardize on a single global platform, increasing consistency and reliability of engineering and project delivery, while systematically reducing your initial installation and operating expenses.



Best-in-class testing

No matter where the system is produced around the world, the same rigorous testing is provided as standard. You can count on Eaton's commitment to quality, beginning in the design phase with full 3rd party type testing to all relevant

IEC standards, right through to factory and on site acceptance testing. In addition to compliance to ISO 9001, all manufacturing locations must adhere to Eaton's quality system to ensure the highest quality standards are delivered.



Basic design

The construction of Power Xpert UX is modular by design. It is custom built to meet your project specific application parameters and has a broad set of features that can be tailored to meet your performance, reliability and safety requirements. The design draws on Eaton's extensive experience in insulation technologies, combining cast resin insulation and fully insulated busbar systems.

The Power Xpert UX platform has three high-voltage compartments separated by earthed metal barriers, providing the highest loss of service continuity classification LSC2B and partition class PM:

1. The busbar compartment

- Pressure relief for venting into the arc channel
- Busbars are fully insulated along their entire length
- Segregation of busbars per panel or number of panels

2. The switching device compartment

- Pressure relief for venting into the arc channel
- Test position included for full functional testing of the switching device without connection to primary power
- Includes all the safety interlocking mechanisms required for safe and reliable operation
- Houses SF₆ free switching devices using cast resin solid insulation technologies to ensure complete segregation and isolation between phases and between phases and earth
- Optional remote racking and operation of the withdrawable switching devices

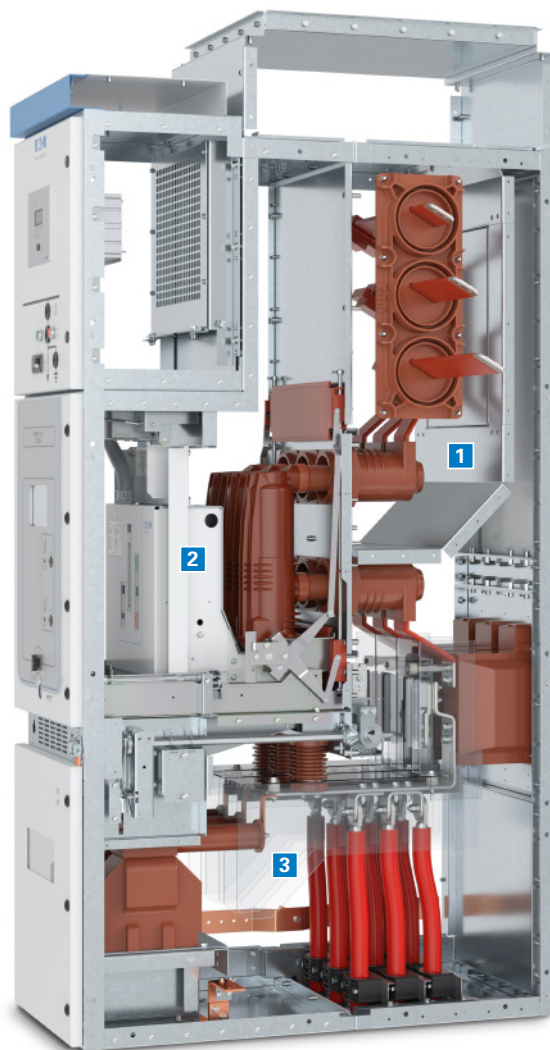

3. The cable compartment

- Pressure relief for venting into the arc channel
- Connection for up to 9 cables per phase
- Provision for connection of primary cables from the front side
- Multiple sets of current transformers per phase
- Fixed/removable or fully withdrawable voltage transformers
- Houses the fixed integral fault making earthing switch, manually operated from the front side
- Optional remote operation of the earthing switch

Pressure relief solutions are available for venting gases either inside or outside of the electrical switch room and can be configured with full or low height arc channels to match your switch room parameters.

The Power Xpert UX is designed for maximum flexibility with switchboards capable of being positioned back to wall, front to front or back to back.

Whatever the **needs** of your application
Power Xpert UX can provide a **solution**



Leading with safety innovation

With proven technologies that offer best-in-class operation and maintenance, our Power Xpert UX system is designed with safety in mind.

Eaton's expertise in switchgear innovation, including cast-resin, vacuum circuit breaker and contactor technologies, arc interruption and electrical field control have been integrated into the design and development of Power Xpert UX. This ensures that the switchgear has the highest levels of safety and operational reliability at all times.

Arc free zones

Fully insulated and isolated current paths reduce the potential for internal faults through the creation of arc free zones.

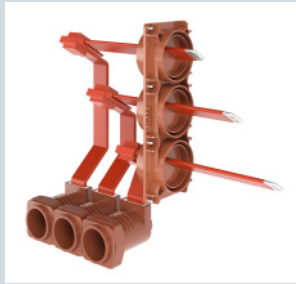

Fully insulated busbar system.

Internal arc classification (IAC) AFLR up to 50kA for 1 second

In the unlikely event of an internal arc fault, the metal enclosed design and robust construction enables the Power Xpert UX system to successfully pass internal arcing tests in accordance with IEC 62271-200. This standard defines the required level of protection in the event of an internal arc fault, in all three primary compartments up to 50kA for 1 second.

The system has been proven by independent 3rd-party testing to provide an internal arc classification (IAC) of AFLR.

- A = Protection for personnel
- F = Protection at the front
- L = Protection at the sides
- R = Protection at the rear

Safety and reliability through accessibility of compartments

Ensuring safety of personnel whether through operation or under maintenance is essential. Restricting access to high-voltage compartments is achieved through design. Power Xpert UX has the following accessibility definitions according to IEC62271-200:

- Busbar compartment: Tool-based / non-accessible
- Switching device compartment: Interlock controlled
- Cable compartment: Tool-based or option for interlock controlled

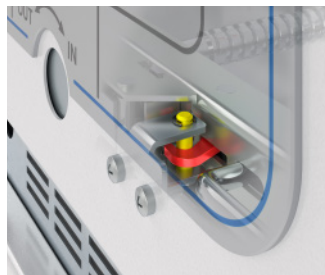

Interlock controlled access to the switching device compartment.



Interlock controlled access to the cable compartment.

Racking behind closed doors

To maximize operator safety Power Xpert UX enables operation of the withdrawable switching device from test to service and back to the test position, all behind closed doors. This ensures full internal arc containment at all times during operation.



Racking behind closed door.

Remote operation

For additional safety, full remote operation of the switchboard is possible without the need to enter the switch room. Operational safety and automation can be further enhanced by including the remote racking option for withdrawable switching devices and the option for remote operation of the integral earthing switches.



Full remote operation.

Continuous 24/7 temperature monitoring

Increased protection through permanently installed self-powered, non-contact infrared sensors that continuously monitor the thermal condition of joints and cable connections. The monitoring system enables detection of hotspots at an early stage of development and provides valuable maintenance data to prevent potential downtime.

Safety interlocks

For personnel safety, the Power Xpert UX system is designed with a number of comprehensive mechanical interlocks according to IEC62271-200 for safe and reliable operation of the switchgear.

- It is not possible to rack-in or rack-out a switching device unless it is in the Off position
- It is not possible to rack-in a switching device to the Service position with the earthing switch in the Closed position
- It is not possible to close a switching device unless the device is in the Service or Test position
- The secondary socket can only be disconnected with the switching device in the Test position
- It is not possible to close the earthing switch when the switching device is in the Service position
- The door of the switching device compartment can only be opened with the switching device in the Test position
- It is only possible to rack-in or rack-out the switching device when the switching device compartment door is closed
- The cable compartment door can only be opened when the earthing switch is in the Closed position
- The earthing switch cannot be opened when the cable compartment door is open



Racking mechanism interlock.

Additional safety features

- Additional electrical or mechanical key interlocks are available to secure safe and reliable operation for busbar earthing and up or downstream interlocking
- Option for full remote control of the switchgear including racking and operation of withdrawable switching devices and remote operation of integral earthing switches
- Busbar earthing options including fixed integral solutions and withdrawable earthing devices
- Optional integrated arc absorber technology used for cooling gasses as a result of an internal fault to vent inside the switch room in a safe manner
- Design focused on single-pole insulation of phases to avoid or minimize the chances of an internal fault
- Rated partition class PM with earthed metal partitions or shutters between sections and compartments

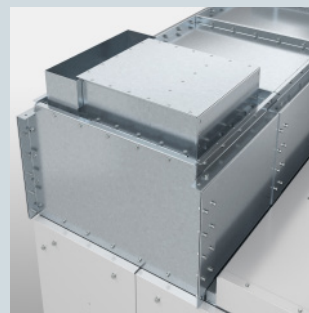

Integrated arc absorber technology.



Partition class PM - opening of metal shutters.



Maximum uptime with minimal maintenance

To maximize uptime and minimize maintenance typical switchgear failure points were analyzed and addressed. Eaton designed the Power Xpert UX system to focus on enhanced reliability and reduced maintenance.

Features

Highest loss of service continuity classification (LSC2B)

Safety of personnel is critical, including during installation and maintenance. The ability to work on an installation without switching off the power to maximize uptime is defined as "Loss of Service Continuity" (LSC). It describes the extent to which the switchgear and control gear are allowed to remain operational in case access to a main circuit compartment is necessary. The Power Xpert UX has the highest classification, LSC2B, as standard. This rating indicates that it is safe to open the switching device compartment when the cables and busbars are energized.

Fully insulated and isolated design

Power Xpert UX utilizes insulating medium throughout the high-voltage current path to create and ensure arc free zones. This increases the lifetime reliability of the system as well as to ensure a safer environment under maintenance.

SF₆-free design

The combination of vacuum interrupters for switching, cast-resin technology and clean air as the isolation medium ensures that the Power Xpert UX is an environmental friendly system. Without SF₆ gas, plant maintenance and operation is simplified and costly administration, SF₆ gas management and end of life disposal costs are minimized.

Vacuum circuit breaker technology

By designing a simple and efficient low energy spring-charged mechanism with the minimum possible number of parts, the maintenance requirements normally associated with this type of mechanism are minimized. The W-VACi breaker is virtually maintenance-free.

Vacuum contactor technology

Developed with cutting-edge technologies, Eaton's withdrawable type vacuum contactor switching devices are world-leading in terms of performance, safety and functionality. With a mechanical life up to 1,000,000 operations contactor switching devices are used in frequently operated loads and harsh environments.

Fully withdrawable voltage transformers

Fully withdrawable voltage transformers with shutters are available for safe operation under live conditions.

Busbar system

The Power Xpert UX busbar system is fully insulated along its entire length with molded supports providing segregation of the busbar chambers to adjacent panels. This ensures maximum integrity and provides a virtually maintenance-free busbar system.

Harsh environment protection

In areas where high-voltage switchgear can be exposed to harsh environments, solutions are available to avoid or minimize the impact to electrical current carrying components.



Eaton's newest range of IEC W-VACi vacuum circuit breakers are virtually maintenance-free.



Independently operated and lockable shutters allow for safe cable or busbar testing while adjacent compartments remain live.

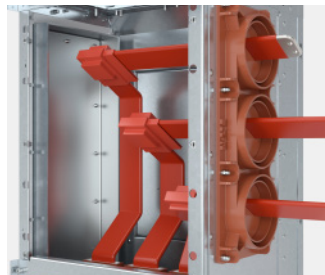

A fully insulated busbar system provides a virtually maintenance-free system.

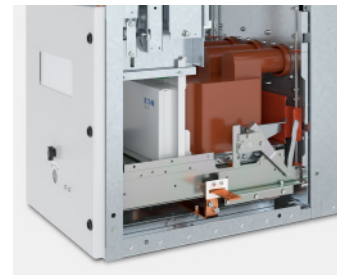

Fully withdrawable voltage transformers with shutters allow safe operation under live conditions with the cable compartment door closed.

Information is uptime

Switchgear failure has the potential to cause production downtime and can lead to costly repair bills and safety concerns. Effective control, protection and system diagnostics are essential to any reliable and safe network.

24/7 thermal monitoring system

By determining potential reliability issues before they occur, uptime can be increased through planned and preventative maintenance. Eaton has partnered with Exertherm, a world leader in continuous thermal monitoring, to provide the Power Xpert UX system with an optional continuous 24/7 temperature monitoring system. Hotspots in joints and cable connections are detected at an early stage of development via permanently installed infrared sensors.

The system provides valuable data for preventative maintenance. Based on real-time data, preventative maintenance can be scheduled to reduce unplanned downtime.

The thermal monitoring system is modular and can be scaled to any size of installation. Local or remote monitoring of the system is possible via local display or web connection.



Panel mounted alarm module connects via MODBUS to the system data cards mounted within the switchgear for local or remote alarm and data logging.

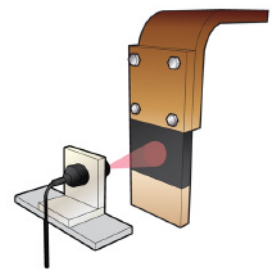

Self-powered, non-contact infrared sensor.

SmartPX downtime avoidance and maintenance system

Eaton's SmartPX™ is an advanced intelligent system for motor control and power distribution. The system provides an extensive range of protection, monitoring and control functions, either locally or via a network. It can be used in a stand-alone mode or integrated into other systems such as DCS and SCADA. The SmartPX system is capable of storing and analyzing data to streamline corrective and preventative maintenance of connected electrical equipment by learning load profiles over time and using that data to predict dangerous trends.

Modern operations require increasingly effective strategies to avoid process downtime. More and more real-time data is required to develop algorithms that monitor the system's health and predict problems. Rather than overloading the system's network with more data, the SmartPX system stores and analyzes local data and sends only relevant alarms and warnings to the upstream system, through push notifications and emails via LAN, WLAN or SMS.

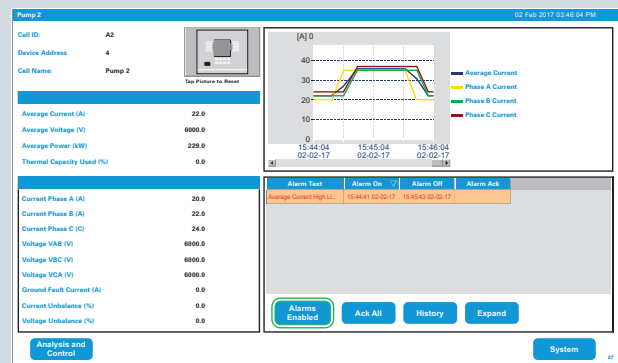

SmartPX logs and trends the total power, current and voltage being used by the power distribution system and stores the data locally. SmartPX software monitors the electrical parameters of your system and detects patterns that may lead to future problems.



Flexibility in a compact footprint

Eaton understands that real estate is a valuable resource. The available space must be optimized to ensure building and land costs are minimized, without compromise to the solution design or functionality.

The footprint of Eaton's Power Xpert UX switchgear is one of the most compact of all systems available on the market. 12/17.5kV vacuum circuit breaker (VCB) panels with rated current of 630/1250A up to 31.5kA are only 600mm wide and 1320mm deep – up to 37% less floor area than similar switchgear solutions on the market.

Along with a compact footprint, the Power Xpert UX system offers flexible design options for the most demanding of applications.

Optional panel and switchgear solutions

- Fused load-break switch panels up to 24kV as an alternative for withdrawable switching devices
- 400mm wide Slimline vacuum contactor panels up to 7.2kV
- 600mm wide vacuum contactor panels up to 12kV
- Single width panel solutions with cables in/out (top/bottom, top/top)
- Back to wall installation
- Back to back, front to front and 'U' shaped configurations
- Top entry solutions for primary and secondary cables
- Bus-duct connections

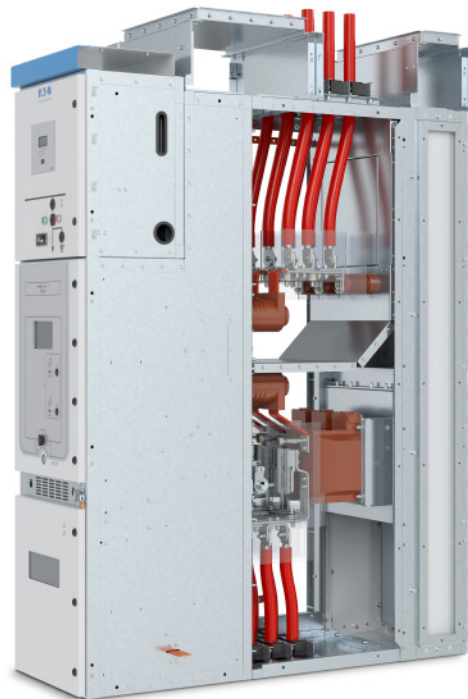

Single width panel solution with cable in/out (top/bottom).

Flexibility in arc channel solutions

- Arc channels provided with integrated arc absorber technology for venting gases inside the switch room, without the need to exhaust to the outside
- Different heights of arc channels are available
- Flexible solutions to connect the arc channel to the wall flange (via sides, front or rear of the installation), in case of venting gases outside the switch room



Arc channel with integral arc absorber.



Low height arc channels.

Space saving solutions

- Current and voltage transformers located in the bus riser
- Voltage transformer and integral fault-making busbar earthing combined in the bus coupler
- Top mounted voltage transformers
- Top mounted integral fault making busbar earthing
- Multiple sets of current transformers per phase
- Fixed/removable and withdrawable voltage transformers
- On board control power transformer (contactor)

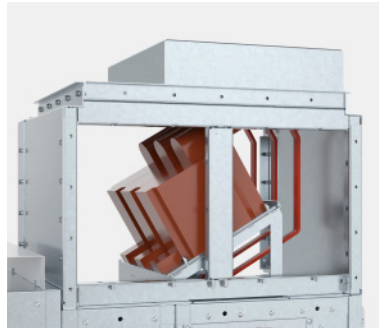

Top mounted voltage transformers.

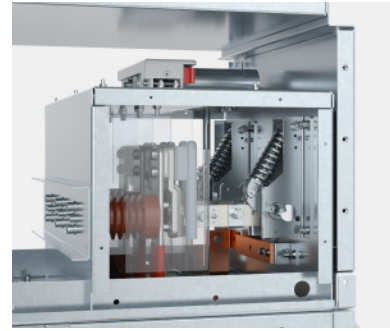

Top mounted integral fault-making busbar earthing.

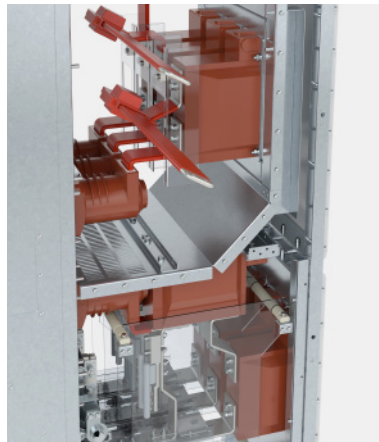

Multiple sets of current transformers per phase.

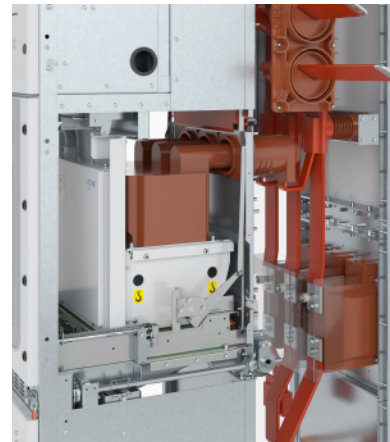

Current and voltage transformers located in the bus riser.

Contact **Eaton** for other project specific solutions

Primary components

Eaton is one of the few global, fully integrated manufacturers of high-voltage switchgear. Utilizing core technologies of vacuum interruption and cast resin insulation, switching devices used within the Power Xpert UX switchgear have outstanding performance including:

- Optimal arc control
- Virtually maintenance-free
- High electrical endurance
- Insensitivity to environment
- SF₆ free
- Long service life

Eaton's industry leading medium voltage technology



Vacuum circuit breakers Type W-VACi

- Type tested in accordance with IEC62271-100
- 12/17.5kV up to 4000A 50kA/3sec.
- 24kV up to 2500A 31.5kA/3sec.
- Wide range of AC or DC auxiliary control voltages
- Full range of accessories
- Optional remote racking capability
- Electrical or mechanical key interlocking options



Vacuum contactors Type W-SLC

- Tested in accordance with IEC 62271-106
- Mid-mount type
- 3.6/7.2/12kV ratings
- Contactor switching up to 400A
- Maximum fuse/contactor combination: 200A
- Breaking capacity with fuse up to 50kA
- Wide range of AC or DC auxiliary control voltages
- On-board contactor control power transformer option
- Optional remote racking capability
- Electrical or mechanical key interlocking options



Vacuum contactors Type W-SLN

- Tested in accordance with IEC 62271-106
- Roll-on floor type
- 3.6/7.2kV ratings
- Contactor switching up to 400A
- Maximum fuse/contactor combination: 400A
- Breaking capacity with fuse up to 50kA
- Wide range of AC or DC auxiliary control voltages
- On-board contactor control power transformer option
- Suitable for integration in 400mm wide Slimline contactor panel
- Electrical or mechanical key interlocking options

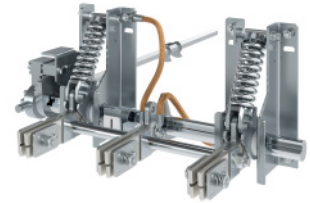

Earthing switch

- Type tested in accordance with IEC62271-102
- 12/17.5kV up to 50kA/3sec. 130kA peak
- 24kV up to 31.5kA/3sec. 80kA peak
- Optional remote operating capability

Secondary equipment for protection and control

Safe and reliable operation of any switchgear is built upon the foundation of a clear, uncomplicated control and protection system. Clarity of operation and ease of use are key fundamentals to world-class control and protection devices.

Safe, accurate protection and control



MRI4

Non-directional feeder protection

With a number of three phase protection elements, the MRI4 provides protection against overcurrent, short-circuit and earth fault. The relay is used for incoming and outgoing feeder protection or as back-up protection for differential protection systems.



MRA4

Directional feeder protection

The MRA4 is a directional protection and control relay with extensive protection functions to a variety of applications such as incoming or outgoing feeder protection, network protection and generator protection.



MCA4

Directional feeder protection

The MCA4 is a precise and reliable protection, control and monitoring relay for feeder, grid and generator applications. The hardware is designed for all nominal values in combination with protection and control functionality.



MRU4

Voltage and frequency protection

Designed to protect electrical equipment from dangerous voltage and frequency fluctuations. The MRU4 offers for example protection against under-voltages caused by mains short-circuits, or over-voltages due to load shedding or failure of a generator voltage controller.



MRM4

Motor protection

The MRM4 provides the necessary functions to protect motors. The protection functions are based on current measurement. The relay is also provided with monitoring functions such as motor start sequence, unbalance and thermal condition of the motor.



MRMV4

Motor protection with voltage measurement

Compared with the MRM4, the MRMV4 also features voltage measurement and is therefore able to monitor power, voltage and frequency.



MCDGV4

Generator differential protection

The generator differential protection relay MCDGV4 is a high precision protection for medium and high power generators. In addition to the phase and earth differential protection, the device provides a variety of generator specific protection functions.



MRDT4

Non-directional transformer differential protection

The various protective functions of the MRDT4 are specifically tailored to the protection of two winding transformers. The device offers in addition to the differential protection various communication and back-up protection functions.



Versatility for different applications

Power distribution and motor control application solutions differ substantially depending on the system, operating practices and site configuration. The Power Xpert UX system offers a versatile system for high-voltage applications to meet requirements for all applications within segments such as:

- Oil and gas
- Marine and offshore
- Data centers
- Power generation
- Metals and mining
- Infrastructure
- Utilities
- Automotive
- Healthcare
- Petrochemical industries

Marine version

The Power Xpert UX system is available in a marine version, designed to specifically meet the conditions on board ships and vessels related to vibration, inclination and environmental challenges.

Marine approvals available:

- Lloyds Register
- DNV
- Bureau Veritas
- American Bureau of Shipping (ABS)

Seismic qualification

The Power Xpert UX system has been tested to withstand the effects of seismic events. The system exceeds the requirements of:

- International Building Code (IBC)
- California Building Code (CBC)
- Uniform Building Code (UBC), Zone 4 requirements
- IEEE Std 693
- ICC-ES AC156



PT. APINDO MITRA SELARAS

Telp. +62 821 2222 8303 - aris@kseindonesia.com
sales@kseindonesia.com - www.kseindonesia.com

Electrical data

System		3.6 kV	7.2 kV	12 kV	17.5 kV	24 kV
Rated voltage	kV	3.6	7.2	12	17.5	24
Impulse withstand voltage	kV	40	60	75	95	125
Power frequency withstand voltage	kV	10	20	28	38	50
Rated frequency	Hz	50/60	50/60	50/60	50/60	50/60
Busbar system						
Rated normal current	A	630 ... 4000				630 ... 2500
Rated short time withstand current	kA/s	25 ... 50/3				20 ... 31.5/3
Rated peak withstand current	kA	63 ... 125				50 ... 80
Circuit-breaker type W-VACi						
Rated nominal current	A	630 ... 4000 (FC)				630 ... 2500
Rated breaking current	kA	25 ... 50/3				20 ... 31.5/3
Rated short-circuit making current	kA	63 ... 125				50 ... 80
Rated short time withstand current	kA/s	25 ... 50/3				20 ... 31.5/3
Contactors type W-SLC						
Rated nominal current	A	400				-
Rated current contactor / fuse combination	A	Max. 200				-
Rated breaking current	kA	50 (limited by the fuse)				-
Rated short time withstand current	kA/s	6/1				-
Rated peak withstand current	kA	15.6				-
Earthing switch						
Rated short-circuit making current	kA	63 ... 130				50 ... 80
Rated short time withstand current	kA/s	25 ... 50/3				20 ... 31.5/3
Contactors type W-SLN (Slimline)						
Rated nominal current	A	400				-
Rated current contactor / fuse combination	A	Max. 400 (double fuse)				-
Rated breaking current	kA	50 (limited by the fuse)				-
Rated short time withstand current	kA/s	6/1				-
Rated peak withstand current	kA	15.6				-
Earthing switch						
Rated short-circuit making current	kA	15.6				-
Rated short time withstand current	kA/s	6/1				-
Internal arc						
Internal arc classification AFLR	kA/s	Up to 50/1				Up to 31.5/1
Enclosure data						
Degree of protection		IP4X (IP41, IP42 or IP44 as an option)				
Loss of service continuity category		LSC2B				
Partition class		PM				
Standard color		RAL7035				

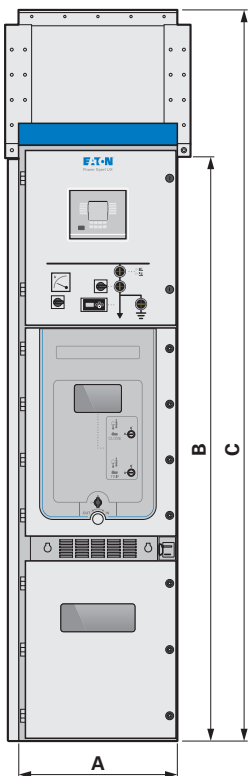

Main dimensions

System	Width A (mm)	Height B (mm)	Height C ¹⁾ (mm)	Depth D (mm)
3.6/7.2kV Slimline contactor	400	2200	2760	1770
3.6/7.2/12kV Mid-mount contactor panel	600	2200	2760	1320
3.6/7.2/12/17.5kV 630A - 25kA	600	2200	2760	1320
1250A - 25/31.5kA	600	2200	2760	1320
2000A - 25/31.5kA	800	2200	2760	1320
2500A - 25/31.5kA	800	2200	2760	1320
1250A - 40/50kA	800	2200	2760	1500
2000A - 40/50kA	800	2200	2760	1500
3150A - 25/31.5/40/50kA	1000	2200	2760	1500
24kV 1250A - 20/25/31.5kA	800	2320	2880	1570
2000A - 20/25/31.5kA	1000	2320	2880	1570
2500A - 20/25/31.5kA	1000	2320	2880	1570

¹⁾ Total height with standard arc channel for venting gases outside the switch room.
For the availability of low height arc channels and integral arc absorber solutions, please contact Eaton.



Local service

When and where you need it

The globalization and standardization of the Power Xpert UX platform go hand in hand with local application engineers, service technicians and operations team.

Eaton offers highly efficient product supply and service at a local level, worldwide. Whether you purchase or use the Power Xpert UX in an industrial area, in a difficult to access oilfield, or down a deep mine, you can depend on the same exceptional product quality, performance, safety, reliability, efficiency and service support.

Additional services can be offered, such as:

- Power system studies
- Configuration and commissioning of protection relays
- Arc flash studies
- Health check of electrical systems
- Preventative maintenance
- Training
- Turn-key delivery of projects including complete E-house solutions



We make what matters work.*



At Eaton, we believe that power is a fundamental part of just about everything people do. That's why we're dedicated to helping our customers find new ways to manage electrical, hydraulic and mechanical power more efficiently, safely and sustainably. To improve people's lives, the communities where we live and work, and the planet our future generations depend upon. Because this is what really matters. And we're here to make sure it works.

To learn more go to: Eaton.com/whatmatters

EATON

Powering Business Worldwide

We make what matters work.

At Eaton, we're energized by the challenge of powering a world that demands more. With over 100 years experience in electrical power management, we have the expertise to see beyond today. From groundbreaking products to turnkey design and engineering services, critical industries around the globe count on Eaton.

We power businesses with reliable, efficient and safe electrical power management solutions. Combined with our personal service, support and bold thinking, we are answering tomorrow's needs today. Follow the charge with Eaton.

Visit Eaton.com/electrical.



PT. APINDO MITRA SELARAS

Telp. +62 821 2222 8303 - aris@kseindonesia.com
sales@kseindonesia.com - www.kseindonesia.com

Eaton
1000 Eaton Boulevard
Cleveland, OH 44122
United States
Eaton.com

© 2017 Eaton
All Rights Reserved
Publication No. BR022008EN
March 2017

Changes to the products, to the information contained in this document, and to prices are reserved; so are errors and omissions. Only order confirmations and technical documentation by Eaton is binding. Photos and pictures also do not warrant a specific layout or functionality. Their use in whatever form is subject to prior approval by Eaton. The same applies to Trademarks. The Terms and Conditions of Eaton apply, as referenced on Eaton Internet pages and Eaton order confirmations.

Eaton is a registered trademark.
All other trademarks are property of their respective owners.

Follow us on social media to get the latest product and support information.



Powering Business Worldwide